

HINTS:

Prepare the area by creating a grid pattern prior to testing.

Perform all Scans on like-surfaced areas such as asphalt, concrete, rock, grass.

Do not test on expansion joints or cracks in the surface.

Be sure rubber pads on actuator and accelerometers are in place.

Patterns in the markings indicate likely pipe location.

A minimum of 5 slices must be taken and 3 rows must be scanned to indicate a pattern.

TERMS:

Slice – individual test point

Scan – A series of slices along a single line

Pipe Map – the results of a single scan

CAUTION:

Always setup a grid at a 90-degree angle from the suspected path of the target line. The APL must be scanned in a perpendicular direction to the target line.

Consult instruction manual for product specifications regarding pipe detection limits.



851 Transport Drive Phone: 219 465 2700
Valparaiso, IN 46383-8432 Web: www.gasleaksensors.com

Innovative Detection Solutions

MADE IN USA

Distributed by:

Quick-Start Instructions

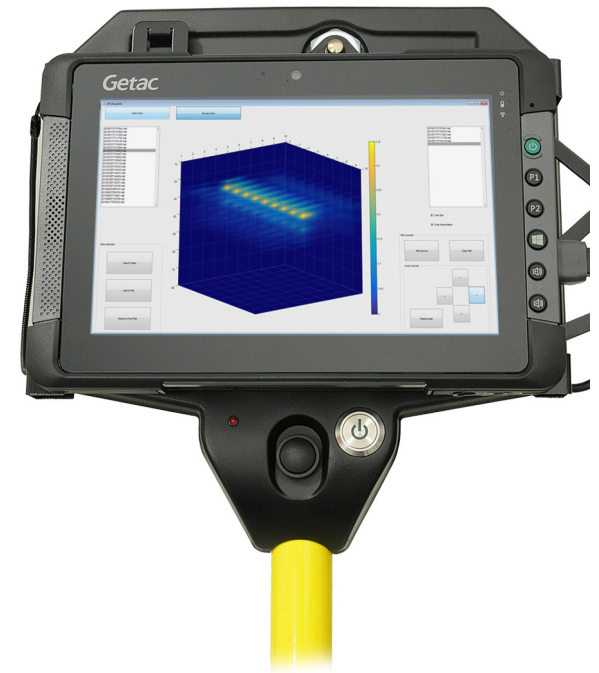

This is not a substitute for the instruction manual. It is for reference only.

Read and understand the instruction manual before use.

ULTRA-TRAC[®] APL

QUICK-START INSTRUCTIONS

STARTING UP THE APL

1. Press and Hold the APL power button until the light begins to flash. Once initialized, the APL power button will glow solid green.
2. Power on the tablet by pressing the tablet power button.
3. The APL application will automatically start. When loading, the SENSIT logo will be displayed.
4. Click the grey "Connect to APL" button. Once connected, the button will turn green.
5. On the bottom right hand corner of the screen, select job settings based on site conditions.
6. Select surface type; Hard or Soft. Site conditions will determine the proper setting. If unsure, consult the manual.
7. Select the suspected depth of the target line, based on system knowledge. If between 12" and 5' deep, select Normal mode. If the line is suspected to be greater than 5' in depth, select Deep.
8. Select scan direction. If stepping to the left, click the left arrow. If stepping to the right, click the right arrow.
9. Select step distance; either 6" or 12". If no known surface structures are present, select 12". If scanning at a surface structure, select 6" for a high resolution scan. (6" interval is used for a higher resolution scan and is recommended for most applications.)
10. When the menu displays "Ready for reading," the APL is ready to collect data. User settings will be displayed at the top of the screen. The APL is now ready to begin a scan.

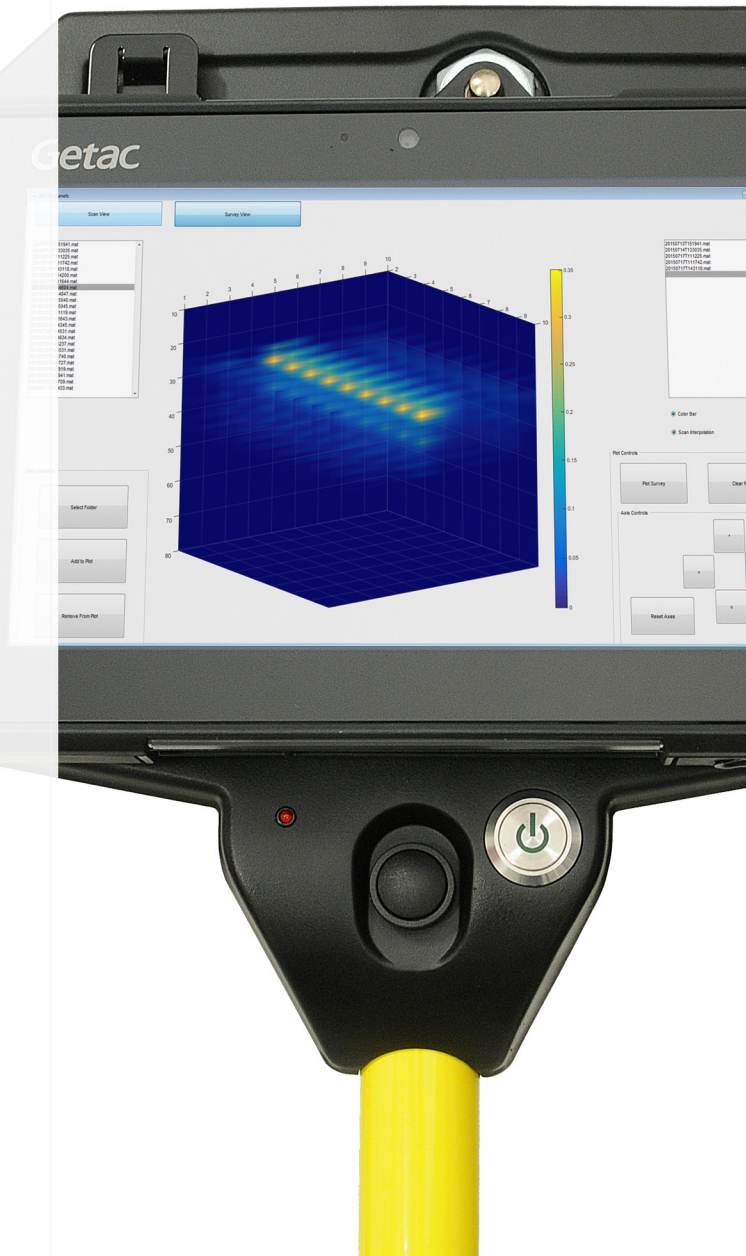

PERFORMING A LOCATE

1. Place measuring device in desired test area. For best results limit the test length (scan) to 10ft.
2. Place instrument on ground adjacent to the first mark on your measuring device.
3. Place foot on footpad.
4. Push the handle firmly forward.
5. Press and release the large black scan button at the top of the handle (just below the control box). Remain stationary and continue to maintain good ground coupling until the APL beeps, indicating data has been collected.
6. Move to the next test location (slice) adjacent to the next 6 or 12 inch mark on the measuring device.
7. Repeat steps 2-6 until scan distance has been completed.
8. Press the "Plot" button to review the Pipe Map Results.
9. Mark the locations on the ground adjacent to the measuring device as shown on the APL.
10. Move measuring device forward or backward 6-10 ft away from current location. Repeat steps 2-9.
11. Repeat scan process as needed to mark location. Press the "New" button to begin a new scan. Press the "Yes" button to use the same settings. Press the "No" button to create new settings. The "Back" button returns to the previous screen.
12. Review marks to determine direction of pipe.